



**IIT Delhi**

**GENERAL RULES**

# COURSES OF STUDY 2024-25



**INDIAN INSTITUTE  
OF TECHNOLOGY DELHI**

[www.iitd.ac.in](http://www.iitd.ac.in)

## VISION

To contribute to India and the World through excellence in scientific and technical education and research; to serve as a valuable resource for industry and society; and remain a source of pride for all Indians.

## MISSION

To generate new knowledge by engaging in cutting-edge research and to promote academic growth by offering state-of-the-art undergraduate, postgraduate and doctoral programmes.

To identify, based on an informed perception of Indian, regional and global needs, areas of specialization upon which the Institute can concentrate.

To undertake collaborative projects which offer opportunities for long-term interaction with academia and industry.

To develop human potential to its fullest extent so that intellectually capable and imaginatively gifted leaders can emerge in a range of professions.

## VALUES

- Academic integrity and accountability.
- Respect and tolerance for the views of every individual.
- Attention to issues of national relevance as well as of global concern.
- Breadth of understanding, including knowledge of the human sciences.
- Appreciation of intellectual excellence and creativity.
- An unfettered spirit of exploration, rationality and enterprise.

# COURSES OF STUDY 2024-2025

**(General Rules)**



**INDIAN INSTITUTE OF TECHNOLOGY DELHI**

Hauz Khas, New Delhi 110 016, India.

<http://www.iitd.ac.in>

**This book is available at the IIT Delhi website:**

<http://www.iitd.ac.in>

Link:<https://home.iitd.ac.in/curriculum.php>

---

**In case of queries, please visit IIT Delhi website or contact:**

**Dean, Academics**

Ph. : +91 11 2659 1708

E-mail : deanacad@admin.iitd.ac.in

**Associate Dean, Academics (Curriculum)**

Ph. : +91 11 2659 1708

E-mail : adcur@admin.iitd.ac.in

**Associate Dean, Academics (PG Research)**

Ph. : +91 11 2659 1708

E-mail : adres@admin.iitd.ac.in

**Associate Dean, Academics (ONI)**

Ph. : +91 11 2659 1708

E-mail : adoni@iitd.ac.in

**Deputy Registrar, Academics**

Ph. : +91 11 2659 1737

E-mail : drpgrs@iitd.ac.in

**Assistant Registrar/Consultant Academics**

Ph. : +91 11 2659 1718 & 8511

E-mail : aracad@admin.iitd.ac.in

---

Copyright : © IIT Delhi

Produced by : Publication Cell, IIT Delhi

July 2024

# CONTENTS

1.	INTRODUCTION .....	1-6
1.1	Background.....	1
1.2	Departments, Centres and Schools .....	1
1.3	Programmes Offered.....	2
1.4	Entry Number.....	6
1.5	Honour Code.....	6
2.	COURSE STRUCTURE AND CREDIT SYSTEM .....	7-14
2.1	Course Numbering Scheme .....	7
2.2	Credit System.....	8
2.3	Assignment of Credits to Courses.....	8
2.4	Earning Credits.....	8
2.5	Description of Course Content .....	9
2.6	Pre-requisite(s) .....	9
2.7	Overlapping/Equivalent Courses.....	9
2.8	Course Coordinator.....	10
2.9	Grading System .....	10
2.10	Evaluation of Performance.....	12
3.	REGISTRATION AND ATTENDANCE .....	15-18
3.1	Registration.....	15
3.2	Registration and Student Status.....	15
3.3	Advice on Courses .....	15
3.4	Validation of Registration.....	15
3.5	Minimum Student Registration in a Course .....	15
3.6	Late Registration .....	15
3.7	Add/Drop, Audit and Withdrawal of Courses .....	16
3.8	Semester Withdrawal.....	16
3.9	Registration in Special Module Courses.....	16
3.10	Registration for Non-graded Units.....	17
3.11	Pre-requisite Requirement(s) for Registration.....	17
3.12	Overlapping/Equivalent Courses.....	17
3.13	Limits on Registration .....	17
3.14	Registration and Fee Payment .....	17
3.15	Continuous Absence and Registration Status.....	17
3.16	Attendance Rule.....	17



## 1. INTRODUCTION

### 1.1 Background

IIT Delhi offers various Undergraduate, Post Graduate and Ph.D. Programmes at the undergraduate level, IIT Delhi provides science-based engineering education with a view to produce quality engineer-scientists. Every B.Tech. student needs to do compulsory foundation courses in the areas of basic sciences, humanities, social sciences and engineering sciences apart from departmental requirements in his/her core engineering discipline. Departmental courses (core and electives) constitute about half of the total curriculum. Further, students do open category electives to develop broad inter-disciplinary knowledge base or to specialize significantly in an area outside the parent discipline. Many activities are included in the undergraduate curriculum as non-graded core with a view to enhance the quality of learning. The curriculum provides broad based knowledge and simultaneously builds a temper for a lifelong process of learning and exploring. At present, IIT Delhi offers 14 B.Tech., 3 Dual Degree (integrated B.Tech. and M.Tech.), and 1 B.Des. programmes.

IIT Delhi also offers multiple Postgraduate Programmes (M.Sc./M. Tech./M.S.(Research)/M.Des./M.B.A./M.P.P./M.A./Ph.D.) through its Departments, Centres, and Schools. Currently, there are 37 M.Tech., 8 Interdisciplinary M.Tech., 18 M.S.(R.), 6 M.Sc., 1 M.Des., 3 M.B.A. (including part time), 1 M.P.P., 1 PG Diploma, and 31 Ph.D. programmes offered by different academic units. In addition, there are 2 joint Ph.D. and 1 joint PG Diploma programmes being offered in collaboration with partner institutions. The Institute has multiple courses at appropriate levels to cater to the academic requirements of the Postgraduate students. New courses are also being continuously added to the existing pool of PG and Pre-Ph.D. courses. At the postgraduate level, students are also encouraged to look beyond their area of specialization to broaden their horizons through open electives and self-learning.

The medium of instruction in the Institute is English.

The Institute follows a semester system. An academic year typically runs from July through June next year and is essentially comprised of two semesters. Typically, the 1<sup>st</sup> semester starts in the last week of July and ends in the 1<sup>st</sup> week of December; the 2<sup>nd</sup> semester starts in the 1<sup>st</sup> week of January and ends in the 2<sup>nd</sup> week of May. Additionally, the summer semester which starts in the 3<sup>rd</sup> week of May and ends in the 2<sup>nd</sup> week of July, is utilized in some exceptional cases. Detailed schedule is given in the Semester Schedule that is made available before the start of each semester.

### 1.2 Departments, Centres and Schools

Each course is offered by an Academic Unit which could be a Department, a Centre or a School. The names of Departments, Centres and Schools and their two-letter codes are given in Table 1. Some programmes are offered jointly by multiple academic units and are classified as interdisciplinary programmes; their codes are given in Table 2.

**Table 1: Academic Departments, Centres, and Schools**

Name of Academic Unit (alphabetical order)	Code of Academic Unit	Course Prefix
Applied Mechanics, Department of	<b>AM</b>	<b>AP</b>
Applied Research in Electronics, Centre for	<b>CR</b>	<b>CR</b>
Artificial Intelligence, Yardi School of	<b>AI</b>	<b>AI</b>
Atmospheric Sciences, Centre for	<b>AS</b>	<b>AS</b>
Automotive Research and Tribology, Centre for	<b>CT</b>	<b>IT</b>
Biochemical Engineering and Biotechnology, Department of	<b>BE</b>	<b>BB</b>
Biological Sciences, Kusuma School of	<b>BL</b>	<b>SB</b>
Biomedical Engineering, Centre for	<b>BM</b>	<b>BM</b>
Chemical Engineering, Department of	<b>CH</b>	<b>CL</b>
Chemistry, Department of	<b>CY</b>	<b>CM</b>
Civil Engineering, Department of	<b>CE</b>	<b>CV</b>
Computer Science and Engineering, Department of	<b>CS</b>	<b>CO</b>
Design, Department of	<b>DD</b>	<b>DD</b>
Electrical Engineering, Department of	<b>EE</b>	<b>EL</b>

Energy Science and Engineering, Department of	<b>ES</b>	<b>XX</b>
Humanities and Social Sciences, Department of	<b>HU/HS</b>	<b>HU/HS</b>
Information Technology, Amar Nath and Shashi Khosla, School of	<b>AN/SI</b>	<b>SI</b>
Interdisciplinary Research, School of	<b>SR</b>	<b>-</b>
Management Studies, Department of	<b>SM</b>	<b>MS/MD</b>
Materials Science and Engineering, Department of	<b>MS</b>	<b>MS</b>
Mathematics, Department of	<b>MA</b>	<b>MT</b>
Mechanical Engineering, Department of	<b>ME</b>	<b>MC</b>
Optics and Photonics, Centre	<b>OP</b>	<b>OP</b>
Physics, Department of	<b>PH</b>	<b>PY</b>
Public Policy, School of	<b>PP</b>	<b>SP</b>
Rural Development and Technology, Centre for	<b>RD</b>	<b>RD</b>
Sensors, Instrumentation and Cyber-Physical Systems Engineering, Centre for	<b>ID</b>	<b>DS</b>
Telecommunication Technology and Management, Bharti School of	<b>BS</b>	<b>BS</b>
Textile and Fibre Engineering, Department of	<b>TT</b>	<b>TX</b>
Transportation Research and Injury Prevention, Centre	<b>TR</b>	<b>TR</b>
Value Education in Engineering, National Resource, Centre for	<b>VE</b>	<b>VE</b>

### 1.3 Programmes Offered

IIT Delhi offers a variety of academic programmes for students with a wide range of backgrounds. Admission to many of these programmes are based on performance in national level tests/entrance examinations. Details are given in the Prospectus.

The programmes offered by IIT Delhi are presently classified as Undergraduate (UG) and Postgraduate (PG) programmes. This classification is based primarily on entry/admission qualification of students rather than the level of degree offered. For all undergraduate programmes, students are admitted after 10+2 years of schooling while for all postgraduate programmes, students are admitted after they have obtained at least a college level Bachelor's degree. Various programmes offered and their specializations are listed below.

#### A. Bachelor of Design: (B.Des.)

Department	Programme	Code
Design	Bachelor of Design	<b>DD1</b>

#### B. Bachelor of Technology: (B.Tech.)

Department	Programme	Code
Applied Mechanics	B.Tech. in Engineering and Computational Mechanics	<b>AM1</b>
Biochemical Engg. and Biotechnology	B.Tech. in Biochemical Engineering and Biotechnology	<b>BB1</b>
Chemical Engineering	B.Tech. in Chemical Engineering	<b>CH1</b>
Computer Science and Engineering	B.Tech. in Computer Science and Engineering	<b>CS1</b>
Civil Engineering	B.Tech. in Civil Engineering	<b>CE1</b>
Electrical Engineering	B.Tech. in Electrical Engineering	<b>EE1</b>
	B.Tech. in Electrical Engineering (Power and Automation)	<b>EE3</b>
Energy Science and Engineering	B.Tech. in Energy Engineering	<b>ES1</b>
Materials Science and Engineering	B.Tech. in Materials Engineering	<b>MS1</b>



Mathematics	B. Tech. in Mathematics & Computing	<b>MT1</b>
Mechanical Engineering	B.Tech. in Mechanical Engineering	<b>ME1</b>
	B.Tech. in Production and Industrial Engineering	<b>ME2</b>
Physics	B.Tech. in Engineering Physics	<b>PH1</b>
Textile and Fibre Engineering	B.Tech. in Textile Technology	<b>TT1</b>

### C. Dual-Degree : (B.Tech. and M.Tech.)

Department	Programme	Code
Chemical Engineering	B.Tech. and M.Tech. in Chemical Engineering	<b>CH7</b>
Computer Science and Engineering	B.Tech. and M.Tech. in Computer Science and Engineering	<b>CS5</b>
Mathematics	B.Tech. and M.Tech. in Mathematics & Computing	<b>MT6</b>

### D. Master of Technology: (M.Tech.)

Department / Centre / School	Programme	Code
Applied Mechanics	M.Tech. in Engineering Analysis and Design	<b>AMA</b>
Biochemical Engg. and Biotechnology	M.Tech. in Biomolecular and Bioprocess Engineering	<b>BEM</b>
Chemical Engineering	M.Tech. in Chemical Engineering	<b>CHE</b>
Chemistry	M.Tech. in Molecular Engg. : Chemical Synthesis & Analysis	<b>CYM</b>
Civil Engineering	M.Tech. in Geotechnical and Geoenvironmental Engineering	<b>CEG</b>
	M.Tech. in Rock Engineering and Underground Structures	<b>CEU</b>
	M.Tech. in Structural Engineering	<b>CES</b>
	M.Tech. in Water Resources Engineering	<b>CEW</b>
	M.Tech. in Construction Engineering and Management	<b>CET</b>
	M.Tech. in Construction Technology and Management (*)	<b>CEC</b>
	M.Tech. in Environmental Engineering and Management	<b>CEV</b>
	M.Tech. in Transportation Engineering	<b>CEP</b>
Computer Science & Engineering	M.Tech. in Computer Science and Engineering	<b>MCS</b>
Electrical Engineering	M.Tech. in Communications Engineering	<b>EEE</b>
	M.Tech. in Computer Technology	<b>EET</b>
	M.Tech. in Control and Automation	<b>EEA</b>
	M.Tech. in Integrated Electronics and Circuits	<b>EEN</b>
	M.Tech. in Power Electronics, Electrical Machines and Drives	<b>EEP</b>
	M.Tech. in Power Systems	<b>EES</b>
Energy Science and Engineering	M.Tech. in Energy & Environment Technologies and Management	<b>ESN</b>
	M.Tech. in Renewable Energy Technologies and Management*	<b>ESR</b>
Materials Science & Engineering	M.Tech. in Materials Engineering	<b>MSM</b>
	M.Tech. in Polymer Science and Technology	<b>MSP</b>
Mechanical Engineering	M.Tech. in Mechanical Design	<b>MEM</b>
	M.Tech. in Industrial Engineering	<b>MEE</b>
	M.Tech. in Production Engineering	<b>MEP</b>
	M.Tech. in Thermal Engineering	<b>MET</b>

Physics	M.Tech. in Applied Optics	<b>PHA</b>
	M.Tech. in Solid State Materials	<b>PHM</b>
Textile and Fibre Engineering	M.Tech. in Fibre Science & Technology	<b>TTF</b>
	M.Tech. in Textile Engineering	<b>TTE</b>
	M.Tech. in Textile Chemical Processing	<b>TTC</b>
Applied Research in Electronics	M.Tech. in Radio Frequency Design and Technology	<b>CRF</b>
Atmospheric Sciences	M.Tech. in Atmospheric-Oceanic Science and Technology	<b>AST</b>
Automotive Research & Tribology	M.Tech. in Electric Mobility	<b>CTE</b>
Biomedical Engineering	M.Tech. in Biomedical Engineering	<b>BMT</b>
Yardi School of Artificial Intelligence	M.Tech. in Machine Intelligence and Data Science	<b>AIB</b>
Interdisciplinary Programme	M.Tech. in Cyber Security	<b>JCS</b>
	M.Tech. in Energy Studies <sup>#</sup>	<b>JES</b>
	M.Tech. in Industrial Tribology and Maintenance Engineering <sup>#</sup>	<b>JIT</b>
	M.Tech. in Instrument Technology	<b>JID</b>
	M.Tech. in Optoelectronics and Optical Communication	<b>JOP</b>
	M.Tech. in Telecommunication Technology Management	<b>JTM</b>
	M.Tech. in Robotics	<b>JRB</b>
	M.Tech. in VLSI Design Tools and Technology (*)	<b>JVL</b>

NOTE: \*Sponsored programmes. #Temporarily suspended.

#### E. Master of Science (Research): M.S.(R)

Department/Centre/School	Programme	Code
Amar Nath and Shashi Khosla School of IT	M.S.(R) in Information Technology	<b>SIY</b>
Applied Mechanics	M.S.(R) in Applied Mechanics	<b>AMY</b>
Atmospheric Sciences	M.S.(R) in Atmospheric and Oceanic Sciences	<b>ASY</b>
Automotive Research and Tribology	M.S.(R) in Automotive Research and Tribology	<b>CTY</b>
Bharti School of Telecommunication Technology and Management	M.S.(R) in Telecommunication Technology and Management	<b>BSY</b>
Biochemical Engineering and Biotechnology	M.S.(R) in Biochemical Engg. and Biotechnology	<b>BEY</b>
Chemical Engineering	M.S.(R) in Chemical Engineering	<b>CHY</b>
Civil Engineering	M.S.(R) in Civil Engineering	<b>CEY</b>
Computer Science and Engineering	M.S.(R) in Computer Science and Engineering	<b>CSY</b>
Electrical Engineering	M.S.(R) in Electrical Engineering	<b>EEY</b>
Energy Science and Engineering	M.S.(R) in Energy Science and Engineering	<b>ESY</b>
Materials Science and Engineering	M.S.(R) in Materials Science and Engineering	<b>MSY</b>
Mechanical Engineering	M.S.(R) in Mechanical Engineering	<b>MEY</b>
Kusuma School of Biological Sciences	M.S.(R) in Biological Sciences	<b>BLY</b>
VLSI Design Tools and Technology	M.S.(R) in VLSI Design Tools and Technology	<b>JVY</b>
Sensors, Instrumentation and Cyber-Physical Systems Engineering	M.S.(R) in Sensors, Instrumentation and Cyber-Physical Systems Engineering	<b>IDY</b>

Transportation Research and Injury Prevention Centre	M.S.(R) in Transportation Safety and Injury Prevention	<b>TRY</b>
Yardi School of Artificial Intelligence	M.S.(R) in Machine Intelligence and Data Science	<b>AIY</b>

#### F. Master of Design: (M.Des.)

Department	Programme	Code
Design	Master of Design in Industrial Design	<b>DDS</b>

#### G. Master of Business Administration: (M.B.A.)

Department	Programme	Code
Management Studies	M.B.A.	<b>SMG</b>
	M.B.A. (with focus on Telecommunication Systems Management)	<b>SMT</b>
	Executive M.B.A. Programme	<b>SMN</b>

#### H. Master of Science: (M.Sc.)

Department	Programme	Code
Chemistry	M.Sc. in Chemistry	<b>CYS</b>
Humanities and Social Sciences	M.Sc. in Cognitive Science	<b>HCS</b>
	M.Sc. in Economics	<b>HES</b>
Mathematics	M.Sc. in Mathematics	<b>MAS</b>
Physics	M.Sc. in Physics	<b>PHS</b>
Biological Sciences	M.Sc. in Biological Sciences	<b>BLS</b>

#### I. Master of Public Policy (M.P.P.)

Department	Programme	Code
School of Public Policy	Master of Public Policy	<b>PPM</b>

#### J. Master of Arts (M.A.)

Department	Programme	Code
Humanities and Social Sciences	MA in Culture, Society, and Thought	<b>HST</b>

#### K. Postgraduate Diploma

Department	Programme	Code
Applied Mechanics	P.G. D.I.I.T (Naval Construction) (for candidates sponsored by the Indian Navy)	<b>AMX</b>
Mechanical Engineering	Joint P.G. Diploma in Visionary Leadership in Manufacturing (VLFM) (Jointly with NITIE Mumbai)	<b>MVX</b>

The DIIT is also awarded under special circumstances in every Master of Technology and M.B.A. programme

listed in item 'D' and 'G' above. It is awarded only to those students who have not been able to complete the requirements of the corresponding M.Tech. degree. For details please see PG Programme Rules, Section 1.6.

**L. Doctor of Philosophy: (Ph.D.)**

All Departments, Centres and Schools listed in Section 1.2 offer Ph.D. programmes. In addition, two joint Ph.D. programmes are offered in association with The University of Queensland Australia and National Yang Ming Chiao Tung University, Taiwan. The two-letter code of the academic unit followed by 'Z' corresponds to the Ph.D. code of the respective academic unit. (e.g. MAZ is the Ph.D. code of the Mathematics Department).

**1.4 Entry Number**

The entry number of a student consists of eleven alpha-numerals, as described below:

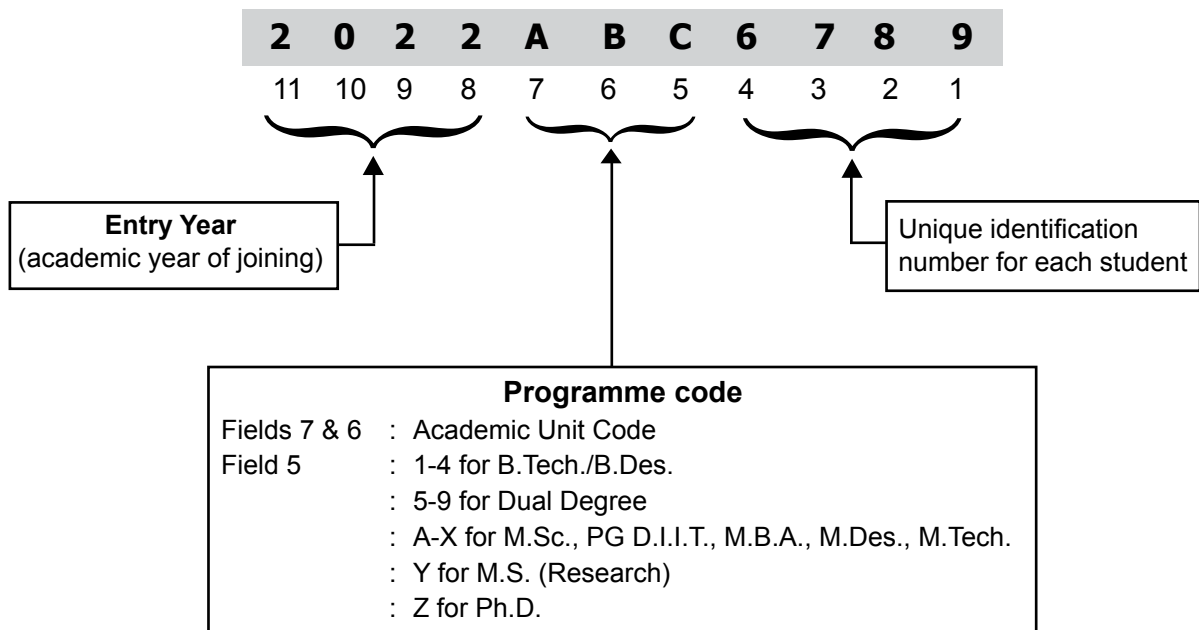

In case of change in Programme by a student, the programme code in his/her entry number (fields 5, 6 and 7) will be changed. However, his/her unique identification number will remain unchanged. Such students will have two entry numbers, one prior to programme change and one after the change. However, any time, only one entry number, that corresponds to the student's present status will be valid and active.

**1.5 Honour Code**

The Honour Code of IIT Delhi is given at the end of this document. Every student signs this Honour Code at the time of admission and is expected to adhere to the Honour Code throughout the period of his/her studies at the Institute.

## 2. COURSE STRUCTURE AND CREDIT SYSTEM

### 2.1 Course Numbering Scheme

Normally every course at IIT Delhi runs for the full length of the semester. Only exception is for V-type courses which may run for part of the semester. A student registers in advance for courses that he/she wants to study and at the end of the semester a grade is awarded. On obtaining a pass grade, the student earns all the credits associated with the course while a fail grade does not get any credit. Partial credits are not awarded.

Each course is denoted by a unique code consisting of three alphabets followed by three numerals:

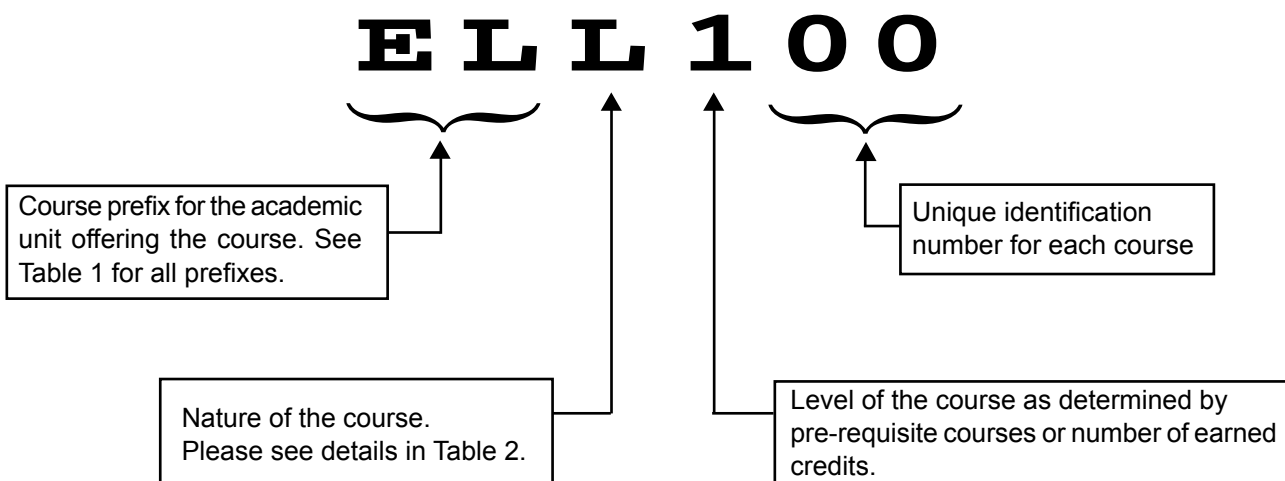

#### (a) Codes for the nature of the course

**Table 2: Codes for the nature of courses.**

Code	Description
<b>D</b>	Project based courses (e.g. Major, Minor, Mini Projects)
<b>L</b>	Lecture courses (other than lecture hours, these courses can have Tutorial and Practical hours, e.g. L-T-P structures 3-0-0, 3-1-2, 3-0-2, 2-0-0, etc.)
<b>N</b>	Non-graded core component
<b>P</b>	Practical/Practice based courses (where performance is evaluated primarily on the basis of practice, practical or laboratory work with LTP structures such as 0-0-3, 0-0-4, 1-0-3, 0-1-3, etc.)
<b>Q</b>	Seminar Courses
<b>R</b>	Professional Practices
<b>S</b>	Independent Study
<b>T</b>	Practical Training
<b>V</b>	Lecture Courses on Special Topics (1 or 2 credits)

#### (b) Level of the course

The first digit of the numeric part of the course code indicates the level of the course as determined by pre-requisite course(s) and/or by the maturity required for registering for the course. The latter requirement is enforced through a requirement of minimum number of earned credits. In general,

100 – 400 level courses : Core and elective courses for UG programmes.  
These courses are not open to any PG student.

- 500 level courses : Courses for M.Sc. programmes.  
These courses are not open to other students.
- 600 level courses : Preparatory/introductory courses for M.Tech. and advanced courses for M.Sc. programmes. 500 and 600 level courses are normally not open to UG students.
- 700 - 800 level courses : Core and elective courses for M.Tech., M.Des., M.B.A., M.S.(Research) and Ph.D. programmes. Usually 800 level courses are advanced courses for PG students.

## 2.2 Credit System

Education at the Institute is organized around the semester-based credit system of study. A student is allowed to attend classes in a course and earn credit for it, only if he/she has registered for that course. Prominent features of the credit system are a process of continuous evaluation of a student's performance/progress and flexibility to allow a student to progress at an optimum pace suited to his/her ability or convenience, subject to fulfilling minimum requirements for continuation and within the maximum allowable period for completion of a degree.

A student's performance/progress is measured by the number of credits that he/she has earned, i.e. completed satisfactorily. Based on the course credits and grades obtained by the student, grade point average is calculated. A minimum grade point average is required to be maintained for satisfactory progress and continuation in the programme. Also, a minimum number of earned credits and a minimum grade point average should be acquired in order to qualify for the degree. All programmes are defined by the total credit requirement and a pattern of credit distribution over courses of different categories as defined in sections 4 and 5 for UG and PG programmes respectively.

## 2.3 Assignment of Credits to Courses

Each course has a certain number of credit(s) or non-graded unit(s) assigned to it depending upon its lecture, tutorial and laboratory/practical contact hours in a week. This weightage is also indicative of the academic expectation that includes in-class contact and self-study outside class hours.

*Lectures and Tutorials* : One lecture or tutorial hour per week over the period of one 14 week semester is assigned one credit.

*Practical/Practice* : One laboratory/practice hour per week over the period of one 14 week semester is assigned half credit.

A few courses are without credit and are counted under non-graded (NG) courses.

**Example :** Course COL334 *Computer Networks*; 4 credits (3-0-2)

The credits indicated for this course are computed as follows:

$$\begin{array}{l}
 3 \text{ hours/week lectures} \quad = 3 \text{ credits} \\
 0 \text{ hours/week tutorial} \quad = 0 \text{ credit} \\
 2 \text{ hours/week practicals} \quad = 2 \times 0.5 = 1 \text{ credit}
 \end{array}
 \left. \vphantom{\begin{array}{l} 3 \\ 0 \\ 2 \end{array}} \right\} \quad \text{Total} = 3 + 0 + 1 = 4 \text{ credits}$$

Total contact hours for the course = (3 h Lectures + 0 h Tutorial + 2 h Practical) per week  
= 5 contact hours per week for 14 weeks.

For each lecture or tutorial credit, the self-study component is 1-2 hours/week (for 100-600 level courses) and 3 hours/week (for 700-800 level courses). The self-study component for practicals is 1 hour for every two hours of practicals per week. In the above example, the student is expected to devote a minimum of 3 + 1 = 4 hours per week on self-study in addition to class contact of 5 hours per week.

## 2.4 Earning Credits

At the end of every semester, a letter grade is awarded in each course for which a student had registered. On obtaining a pass grade, the student accumulates the course credits as earned credits. An undergraduate student has the option of auditing some courses within the credit requirements for graduation. Grades obtained in audit courses are not counted for computing of grade point average. However, a pass grade is essential for earning credits from an audit course. Section 2.9 defines the letter grades awarded at IIT Delhi and specifies the minimum grade for passing a course.

## 2.5 Description of Course Content

Course content description consists of following components: (i) Course Number, (ii) Title of the Course, (iii) Credit and L-T-P, (iv) Pre-requisite(s) and overlapping courses, if any, and (v) List of broad topics covered in the course. Content descriptions for all courses are given in section 10 of this document. An example course content description of a 100 level course is as follows:

### **MTL100 Calculus**

4 Credits (3-1-0)

Review of Limit, Continuity and Differentiability, uniform continuity, Mean Value Theorems and applications, Taylor's Theorem, maxima and minima, sequences and series, limsup, liminf, convergence of sequences and series of real numbers, absolute and conditional convergence.

Reimann Integral, fundamental theorem of integral calculus, applications of definite integrals, improper integrals, beta and gamma functions.

Functions of several variables, limit and continuity, partial derivatives and differentiability, gradient, directional derivatives, chain rule, Taylor's theorem, maxima and minima and method of Lagrange Multipliers.

Double and triple integration, Jacobian and change of variables formula. Parametrization of curves and surfaces, vector fields, divergence and curl, line integrals, Green's theorem, surface integral, Gauss and Stokes theorems with applications.

## 2.6 Pre-requisite(s)

Each course, other than 100 level courses, may have specified pre-requisite(s) which may be other course(s), or a minimum number of earned credits, or both. A student who has not obtained a pass grade in the pre-requisite(s) specified or has not earned requisite number of credits will not be eligible to register for that course. For example:

### **TXL372 Speciality Yarns and Fabrics**

2 Credits (2-0-0)

Pre-requisite(s): TXL222 and TXL232

A student who has obtained a pass grade in TXL222 and TXL232 will be eligible to register for this course.

For UG students, the Pre-requisite(s) for some courses of special nature are given below.

Independent Study	65 earned credits
Mini Project	65 earned credits
Minor Project (Dual Degree)	100 earned credits
B.Tech. Project Part - I	100 earned credits
B.Tech. Project Part - II	Minimum B Grade in B.Tech. Project Part - I
M.Tech. Major Project Part-I (Dual Degree)	135 earned credits

In addition to any pre-requisite specified for 700 and 800 level courses, a UG student needs to earn 75 and 100 credits to register for 700 and 800 level courses, respectively.

## 2.7 Overlapping/Equivalent Courses

Wherever applicable, overlapping and equivalent courses have been identified for each course. A student is not permitted to earn credits by registering for more than one course in a set of overlapping/equivalent courses. Departments/Centres/Schools may use these overlapping/equivalent courses for meeting degree/pre-requisite requirements in special circumstances. For example:

### **CLL113 Numerical Methods in Chemical Engineering**

4 Credits (3-0-2)

Overlaps with: MTL107, MTP290, MTL445, CVL734, COL726

A student who has earned a pass grade in CLL113 will not be eligible to register for MTL107, MTP290, MTL445, CVL734 or COL726. An overlapping course cannot serve as a substitute for a core course of his/her programme. In the above example, if MTL107 is a core course for a student, he/she is not allowed to register for CLL113 as a substitute for this core course.

## 2.8 Course Coordinator

Every course is usually coordinated by a member of the teaching staff of a Department/Centre/School in a given semester. This faculty member is designated as the Course Coordinator. He/she has the full responsibility for conducting the course, coordinating the work of other members of the faculty and teaching assistants involved in that course, administering assignments, conducting the tests as well as moderating and awarding the grades. For any difficulty related to a course, the student is expected to approach the respective course coordinator for advice and clarification. The distribution of the weightage for tests, quizzes, assignments, laboratory work, workshop and drawing assignment, term paper, etc. that will be the basis for award of grade in a course will be decided by the course coordinator of that course, in consultation with other teachers involved, and announced at the beginning of the semester.

## 2.9 Grading System

The grade obtained in a course reflects a student's performance in the course. While relative standing of the student is indicated by his/her grades, the process of awarding grades is not necessarily based upon fitting the marks scored by the students to some statistical distribution. The course coordinator and associated faculty for a course formulate appropriate procedure to award grades that are reflective of the student's performance vis-à-vis the expected learning outcomes of the course.

### 2.9.1 Grade points

The grades and their equivalent numerical points (referred to as Grade Points) are listed in Table 3.

**Table 3: Grades and their description.**

Grade	Grade points	Description
A	10	Outstanding
A (-)	9	Excellent
B	8	Very good
B (-)	7	Good
C	6	Average
C (-)	5	Below average
D	4	Marginal
E	2	Poor
F	0	Very poor
I	-	Incomplete
NP	-	Audit pass
NF	-	Audit fail
W	-	Withdrawal
X	-	Project/ Ph.D. Continuation
S	-	Satisfactory completion
Z	-	Course continuation
U	-	Unsatisfactory progress in Ph.D.

### 2.9.2 Description of grades

#### **A** grade

An 'A' grade stands for outstanding achievement. The minimum marks for award of an 'A' grade is 80 %. However, individual course coordinators may set a higher marks requirement for awarding an 'A' grade.



## **C** grade

The 'C' grade stands for average performance. This is the minimum grade required to pass in the Major Project Part 1 and Part 2 of Dual degree and 2 year M.Tech. and M.S.(R) Programmes.

## **D** grade

The 'D' grade stands for marginal performance; i.e. it is the minimum passing grade in any course excluding the M.Tech. Major Project. The minimum marks for award of 'D' grade is 30 %. However, individual course coordinators may set a higher marks requirement.

## **E** and **F** grades

A student who has scored at least 20% aggregate marks in a subject can be awarded an 'E' Grade. The Course Coordinators are, however, free to enhance this limit but should keep the percentage about 10% less than the cut-off marks for 'D' Grade. The Course Coordinators can also specify any additional requirements (to be specified at the beginning of the Semester) for awarding 'E' Grade. Students who obtain an 'E' Grade will be eligible to appear in a repeat major test (re-major test), an examination with weightage same as that of Major test, for only lecture courses ('L' Category Courses described in section 2.1). If they perform satisfactorily, they become eligible for getting the grade converted to a 'D' Grade, otherwise they will continue to have 'E' Grade. The student will have only one chance to appear for re-major for an 'E' Grade. The re-major test will be conducted within the first week of the next semester. The date of re-major test of Institute core courses for undergraduate students will be centrally notified, while for all other courses, the date would be announced by the respective course coordinators. A student can appear for a maximum of three such re-major tests in a given semester. If a student cannot appear for the re-major test due to any reason(s), he/she will not get any additional chance.

If a student with 'E' grade in a course does not pass the course through a re-major test or obtains an 'F' grade in the course, he/she has to repeat the course if it is a core course. In case the course is an elective, the student may take the same course again or any other course from the same category. 'E' and 'F' Grades are not counted in the calculation of the CGPA; however, these are taken into account in the calculation of the SGPA. (Please see 2.10 for definitions)

## **I** grade

An 'I' grade is temporarily awarded to a student on his/her request to denote incomplete performance in L (lecture), P (practical), V (special module) category courses. Requests for 'I' grade should be made at the earliest but not later than the last day of major tests. An 'I' grade is awarded in case of absence on medical grounds or other special circumstances, before or during the major examination period, provided the student has met the attendance criterion of the course. Attendance in the course for which 'I' grade is being sought will be certified by the course coordinator of the course.

The course coordinators can instruct all students awarded 'I' grade as well as 'E' grade to appear for a common re-major test. All evaluation requirements for such students in the corresponding course(s) should be completed before the end of the first week of the next semester. Upon completion of all course requirements, the 'I' grade is converted to a regular grade (A to F, NP or NF).

## **NP** and **NF** grades

These grades are awarded in a course that the student opts to audit. Only elective courses can be audited. Auditing a course is allowed until a date stipulated in the semester schedule. The audit pass (NP) grade is awarded if the student's attendance is above 75% in the class and he/she has obtained at least 'D' grade. The course coordinator can specify a higher criterion, at the beginning of the semester, for audit pass. If the stipulated requirements are not fulfilled, the audit fail (NF) grade is awarded. The grades obtained in an audit course are not considered in the calculation of SGPA, CGPA or DGPA. However, for undergraduate students, the credits will be counted in total earned credits in the respective category, subject to the maximum allowable limit for audit.

## **W** grade

A 'W' grade is awarded in a course from which the student has opted to withdraw. Withdrawal from a course is permitted until the date specified in the Semester Schedule. Withdrawal from PG major project part 2 is allowed only if he/she is given semester withdrawal. The W grade is mentioned on the grade card.

## X grade

The 'X' grade is awarded for incomplete work in Independent Study, Mini Project, Minor Project, or Major Project Part-1 and Part-2, based on the request of the student. On completion of the work, 'X' grade can be converted to a regular grade within the first week of the next semester. Otherwise, the student will be awarded 'X' grade on a permanent basis and it will appear in his/her grade card. Further, the student will be required to register for the course in the next semester. The credits of the course will be counted towards his/her total load for the semester. In case of Major Project Part-1, the student will not be permitted to register for Major Project Part 2 simultaneously as Major Project Part-1 is a pre-requisite for Major Project Part-2. A regular full-time student can be awarded 'X' grade only once in a course, other than the summer semester. A part-time M.Tech. student is permitted a maximum of two X-grades in the Major Project Part-2.

## S and Z grades

The 'S' grade denotes satisfactory performance and completion of a course. The 'Z' grade is awarded for non-completion of the course requirements, and if it is a core course, the student will have to register for the course until he/she obtains the 'S' grade. The specific courses in which 'S' or 'Z' grades are awarded for undergraduate students are:

- (i) Introduction to Engineering and Programme
- (ii) Language and Writing skills
- (iii) NCC /NSO/NSS
- (iv) Professional Ethics and Social Responsibility
- (v) Communication Skills/Seminar
- (vi) Design/Practical Experience

Besides, summer/winter internships in some PG programmes are also awarded S/Z.

## 2.10 Evaluation of Performance

The performance of a student will be evaluated in terms of three indices, viz., the Semester Grade Point Average (SGPA) which is the Grade Point Average for a semester, Cumulative Grade Point Average (CGPA) which is the Grade Point Average for all the completed semesters at any point in time, and Degree Grade Point Average (DGPA). Degree Grade Point Average (DGPA) is calculated on the basis of the best valid credits in each category, after graduation requirements in all categories are met.

The Earned Credits (E.C.) are defined as the sum of credits for courses in which a student has been awarded pass grades. Points secured in a semester =  $\Sigma$  (Course credits  $\times$  Grade point for all courses in which pass grade has been obtained). The SGPA is calculated on the basis of grades obtained in all courses the student registered for, in the particular semester, except audit courses.

$$\text{SGPA} = \frac{\text{Points secured in the semester}}{\text{Credits registered in the semester, excluding audit and S/Z grade courses}}$$

The CGPA is calculated on the basis of pass grades obtained in all completed semesters, except audit courses and courses in which S/Z grade is awarded.

$$\text{CGPA} = \frac{\text{Cumulative points secured in courses with pass grades}}{\text{Cumulative earned credits, excluding audit and S/Z grade courses}}$$

Examples of these calculations are given in Tables 4(a) and 4 (b).

**Table 4 (a): Typical academic performance calculations - Semester I**

Course no.	Course credits	Grade awarded	Earned credits	Grade points	Points secured
(column 1)	(column 2)	(column 3)	(column 4)	(column 5)	(column 6)
MTLXXX	5	C	5	6	30
COLXXX	4	C (-)	4	5	20
PYLXXX	4	A	4	10	40
PYPXXX	2	B	2	8	16
MCLXXX	4	E	0	2	08
TXNXXX	2	S	2	—	—

Credits registered in the semester (total of column 2) = 21

Credits registered in the semester excluding audit and S/Z grade courses = 19

Earned credits in the semester (total of column 4) = 17

Earned credits in the semester excluding audit and S/Z grade courses = 15

Points secured in the semester (total of column 6) = 114

Points secured in the semester in all passed courses (total of column 6 and pass grade) = 106

$$\text{SGPA} = \frac{\text{Points secured in the semester}}{\text{Credits registered in the semester, excluding audit and S/Z grade courses}} = \frac{114}{19} = 6.000$$

$$\text{CGPA} = \frac{\text{Cumulative points secured in courses with pass grades}}{\text{Cumulative earned credits, excluding audit and S/Z grade courses}} = \frac{106}{15} = 7.067$$

Semester performance: Earned credits (E.C.) = 17      SGPA = 6.000

Cumulative performance: Earned credits (E.C.) = 17      CGPA = 7.067

**Table 4 (b): Typical academic performance calculations - semester II**

Course no.	Course credits	Grade awarded	Earned credits	Grade points	Points secured
(column 1)	(column 2)	(column 3)	(column 4)	(column 5)	(column 6)
MTLXXX	5	B	5	8	40
ELLXXX	4	A (-)	4	9	36
CMLXXX	4	W	—	—	—
CMPXXX	2	B (-)	2	7	14
MCLXXX	4	C	4	6	24
APLXXX	4	A	4	10	40
NLNXXX	1	S	1	—	—

Credits registered in the semester (total of column 2) = 24

Credits registered in the semester excluding audit and S/Z grade courses = 23

Earned credits in the semester (total of column 4) = 20

Earned credits in the semester excluding audit & S/Z grade courses = 19

Points secured in this semester (total of column 6) = 154

Points secured in this semester in all passed courses (*total of column 6 & A-D grade*) = 154

Cumulative points secured = 106 (I semester) + 154 (this sem.) = 260

Cumulative earned credits = 17 (I semester) + 20 (this sem.) = 37

$$\text{SGPA} = \frac{\text{Points secured in the semester}}{\text{Credits registered in the semester, excluding audit and S/Z grade courses}} = \frac{154}{19} = 8.105$$

$$\text{CGPA} = \frac{\text{Cumulative points secured in courses with pass grades}}{\text{Cumulative earned credits, excluding audit and S/Z grade courses}} = \frac{106 + 154}{15 + 19} = 7.647$$

Semester performance: Earned credits (E.C.) = 20      SGPA = 8.105

Cumulative performance: Earned credits (E.C.) = 37      CGPA = 7.647

On completing all the degree requirements, the degree grade point average, DGPA, will be calculated and this value will be indicated on the degree/diploma. **The DGPA will be calculated on the basis of category-wise best valid credits required for graduation.**

A student, who has earned the requisite credits but does not meet the graduation DGPA requirement, may do additional courses in any elective category to meet the DGPA requirement within the maximum permissible time limit.

### 3. REGISTRATION AND ATTENDANCE

#### 3.1 Registration

Registration is a very important procedural part of the academic system. The registration procedure ensures that the student's name is on the roll list of each course that he/she wants to study. **No credit is given if the student attends a course for which he/she has not registered.** Registration for courses to be taken in a particular semester will be done according to a specified schedule before the end of the previous semester. Each student is required to complete the registration process on the web-based system. The student must also take steps to pay his/her dues before the beginning of the semester. Students who do not make payments by a stipulated date can be de-registered for the particular semester.

Students have to report on the date prescribed by office of Dean Academics to mark his/her attendance in person, before the start of Semester. This is a requirement for validation of registration of existing students.

In-absentia registration or registration after the specified date will be allowed only in rare cases at the discretion of Dean, Academics. In case of illness or absence during registration, the student should intimate the same to his/her Programme Coordinator and Dean, Academics.

Brief description of registration related activities is given in the following paragraphs. The relevant dates are included in the Semester Schedule that is made available before the start of the semester. There may be changes in the schedule and/or procedure of registration from time to time. The students are intimated through e-mail about any such change to the e-mail address allocated to each student by the Institute at the time of admission. **This e-mail address is the only channel through which the Institute would communicate with the student. For cyber security reasons, e-mail accounts/kerberos logins that are not used for a certain length of time are disabled and such accounts locked/deleted by the Institute. Students must therefore login into their e-mail accounts/kerberos logins regularly.**

#### 3.2 Registration and Student Status

Failure to register before the last date for late registration will imply that the student has discontinued studies and his/her name will be struck off the rolls.

All registered students, except part-time postgraduate students and visiting students, are considered as full-time students at the Institute. They are expected to be present at the Institute and devote full time to academics and co-curricular and extra-curricular activities in the campus.

#### 3.3 Advice on Courses

At the time of registration, each student must finalize the academic programme, keeping in view factors such as, minimum/maximum numbers of total and lecture credits, past performance, backlog of courses, SGPA/CGPA, pre-requisite(s), work-load and student's interests, amongst others. Special provisions exist for advising academically weak students. Details are given in UG Programme Rules, Section 1.7.

#### 3.4 Validation of Registration

Before the commencement of classes of each semester, on a date specified in the Semester Schedule, every student including part-time students, is required to be present on campus and validate his/her registration by logging into the website. Students who do not do registration validation will not be permitted to add/drop courses.

#### 3.5 Minimum Student Registration in a Course

Undergraduate courses (of 100, 200, 300, or 400 level) and M.Sc. courses (500 or 600 level) will run if a minimum of 12 students register for the course. Under special circumstances, a departmental elective course may be allowed to run with minimum registration of 8 students, with prior permission of Chairperson, Senate. A 700 or 800 level course can run with a minimum of 4 students. This requirement will be verified on the last date for Add/Drop. Courses without the minimum enrolment will be dropped. The students who had registered for these courses will be de-registered, and they will be given one more day for adding a course in lieu of the dropped course.

#### 3.6 Late Registration

For reasons beyond his/her control, if a student is not able to register or send an authorized representative with a medical certificate, he/she may apply to the Dean, Academics for late registration. Dean, Academics will

consider and may approve late registration in genuine cases on payment of an extra fee called late registration fee. Late registration is permitted until a date specified in the Semester Schedule, typically one week after the beginning of the semester.

### 3.7 Add/Drop, Audit and Withdrawal of Courses

- a) **Add/Drop:** A student has the option to add courses that he/she has not registered for or drop courses for which he/she has already registered for. This facility is restricted to a period stipulated in the Semester Schedule, during the first week of the semester, subject to vacancy status of the courses concerned.
- b) **Audit:** A student may apply for changing a credit course to an audit course before a deadline specified in the Semester Schedule.
- c) **Withdrawal:** A student who wants to withdraw from a course should apply before a deadline specified in the Semester Schedule. A withdrawal grade (W) will be awarded in such cases.

Appropriate web-based applications are to be used for availing of the above-mentioned options.

### 3.8 Semester Withdrawal

Semester withdrawal and absence for a semester under different conditions, viz. (i) medical and personal grounds (ii) industrial internship (iii) exchange/deputation to another academic institution in India or abroad, and (iv) disciplinary condition can be granted on application. The condition as per the following should be clearly specified in the application.

- (a) Semester Withdrawal (SW) reflects the condition, in which a student is forced to withdraw from all courses in the semester for medical conditions, or for a part-time student when he/she is sent for an outstation assignment by his/her employer. A student can apply for semester withdrawal if he/she has missed 20 or more teaching days on these grounds. Under no circumstances will an application for semester withdrawal be accepted after the commencement of major tests. A student is not permitted to request for semester withdrawal with retrospective effect.
- (b) Semester Leave (SL) indicates the situation in which a student is permitted to take one or more semesters off for industrial internship or any other assignment with prior approval and planning. The application is to be routed through his/her advisor/programme coordinator and Head of the concerned Department/Centre/School. Dean, Academics is the final approving authority for such requests. All such applications must be processed before the beginning of the semester in which the leave will be taken. At present, UG students are allowed one extra semester for completion of the programme for every semester leave for industrial internship. Such students are permitted a maximum of two semesters of leave. The full-time 2 year M. Tech. /M.S.(R) students would be permitted a maximum of one semester leave for industrial internship or other assignment as approved by the Dean. These semesters will not be counted towards the maximum permitted time period for completion of the degree similar to the provision for UG students.
- (c) When a student registers at another academic institution in India or abroad with the expectation of credit transfer or research work through a pre-approved arrangement including an MoU, the student should be considered as being on a Semester Exchange (SE). The SE period will be counted towards the total period permitted for the degree.
- (d) When a student is suspended for one or more semesters on disciplinary grounds, the student status should be called Disciplinary Withdrawal period (DW).
- (e) UG student may go for a long Internship or spend a semester on a Technical Start-up with the prior approval of the DPE Committee of the Department.

### 3.9 Registration in Special Module Courses

Special module courses, i.e. 'V'-category courses, are 1 or 2 credit courses that can be offered at the beginning of the semester and the regular registration procedure will be followed. A 'V'-category course may also be offered during the semester. In such a case, students will be allowed to add this course before classes for the course begin. These courses will usually cover specialized topics that are not generally available in the regular courses. Eligible students can register for these courses. The course coordinator will evaluate the students' performance and award a letter grade. The credits so earned will count towards the appropriate category for degree completion purposes.

### 3.10 Registration for Non-graded Units

Details pertaining to registration and other modalities of earning non-graded units are given in UG Programme Rules, Section 4.

### 3.11 Pre-requisite Requirement(s) for Registration

A student can register for a course only if he/she fulfills the pre-requisite requirement(s). Request for relaxation of pre-requisite requirement(s) may be raised by students under special circumstances. Such a request needs approval of the Departmental Faculty Advisor and Chairperson Grades and Registration.

### 3.12 Overlapping/Equivalent Courses

A student is not allowed to earn credits from two overlapping/equivalent courses. Overlapping/equivalent courses, wherever applicable, are specified in the Description of Course Contents.

### 3.13 Limits on Registration

An undergraduate student should register for a minimum of 12 credits in a semester. The number of credits a UG student can register in a semester will be limited to 24 for the first 5 semesters with a provision to allow registration upto 26 credits for upto 2 semesters during the entire period of study. A student on probation can register upto 18 credits in a semester. This can be relaxed in 8th / 10th or later registered semester for B.Tech. /Dual Degree students, respectively.

### 3.14 Registration and Fee Payment

Every registered student must pay the stipulated fees in full before the specified deadlines. In the event that a student does not make these payments, he/she can be de-registered from all courses and his/her name can be struck off from the rolls.

### 3.15 Continuous Absence and Registration Status

If a student is absent from the Institute for more than four weeks without notifying the Head of Department/ Centre/School or Dean, Academics, his/her registration will be terminated and name will be removed from the Institute rolls.

### 3.16 Attendance Rule

It is mandatory for the students to attend all classes. Attendance Records of all students for each course will be maintained.

The Course Coordinator will announce the class policy on attendance with respect to grading etc., at the beginning of the semester. This shall be done keeping in mind the importance of classroom learning in the teaching-learning process. Once the class attendance policy has been made clear to all the students registered for the course, the Course Coordinator will implement the same in totality.

For the purpose of attendance calculation, every scheduled practical class will count as one unit irrespective of the number of contact hours.

Attendance record will be maintained based upon roll calls (or any equivalent operation) in every scheduled lecture, tutorial and practical class. Students are required to strictly adhere to and comply with any method or device employed by the Course Coordinator/Instructor for purpose of Attendance Recording. Failure to do so may call for disciplinary action. The course coordinator will maintain and consolidate attendance record for the course (lectures, tutorials and practicals together, as applicable).

A Course Coordinator may choose any one or more of the following as attendance policy.

- (a) The Course Coordinator can assign 10% of the total marks to surprise quiz(zes). If attendance of the student is greater than 90%, result of the best three quizzes will be considered, else average of all quizzes will be considered.
- (b) The Course Coordinator can allocate specific marks for participation in discussions in the class on a regular basis.



- (c) If a student's attendance is less than 75%, the student will be awarded one grade less than the actual grade that he/she has earned. For example, a student who has got an A grade but has attendance less than 75% will be awarded an A (-) grade.
- (d) A student cannot get NP for an audit course if his/her attendance is less than 75%.

The Course Coordinator can implement any other attendance policy provided the policy is approved by the Dean, Academics.

Attendance statistics will also be used in the following way:

- (a) If a student's attendance is less than 75% in more than two courses without any valid reason in a semester, he/she will be issued warning and put under probation. If this is repeated, he/she will not be allotted a hostel seat in the next semester.
- (b) If a student's attendance is less than 75% in any course or CGPA is less than 7.0, then he/she will not be eligible to hold any position of responsibility in the hostel/institute in the next semester.











# INDIAN INSTITUTE OF TECHNOLOGY DELHI

## THE HONOUR CODE

I ....., Entry  
No..... do hereby undertake that as a student at IIT Delhi :

- 1) I will not give or receive aid in examinations; that I will not give or receive unpermitted aid in class work, in preparation of reports, or in any other work that is to be used by the instructor as the basis of grading; and
- 2) I will do my share and take an active part in seeing to it that others as well as myself uphold the spirit and letter of the Honour Code.

I realise that some examples of misconduct which are regarded as being in violation of the Honour Code include :

-  Copying from another's examination paper or allowing another to copy from one's own paper;
-  Unpermitted collaboration;
-  Plagiarism;
-  Revising and resubmitting a marked quiz or examination paper for re-grading without the instructor's knowledge and consent;
-  Giving or receiving unpermitted aid on take home examinations;
-  Representing as one's own work, the work of another, including information available on the internet;
-  Giving or receiving aid on an academic assignment under circumstances in which a reasonable person should have known that such aid was not permitted; and
-  Committing a cyber-offence, such as, breaking passwords and accounts, sharing passwords, electronic copying, planting viruses, etc.

I accept that any act of mine that can be considered to be an Honour Code violation will invite disciplinary action.

Date.....

Student's Signature.....

Name.....

Entry No.....



INDIAN INSTITUTE OF TECHNOLOGY DELHI

Hauz Khas, New Delhi-110016, India

[www.iitd.ac.in](http://www.iitd.ac.in)